

NOTE: BREAK ALL CORNERS WITH 0.015" (.38 MM) RADIUS UNLESS OTHERWISE NOTED. STANDARD TOLERANCES TO APPLY UNLESS OTHERWISE SPECIFIED.

CUSTOMER	CAN ART STD.	DIE No. EH04012	REV. No. 1
DESCRIPTION 1.000 x 0.750 x 0.120 THK. RECT. TUBE w/ ROUND CORNERS	CUSTOMER PART No.	QUOTE No. 13-0555-1	PROPOSAL No. H-28125

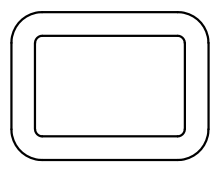
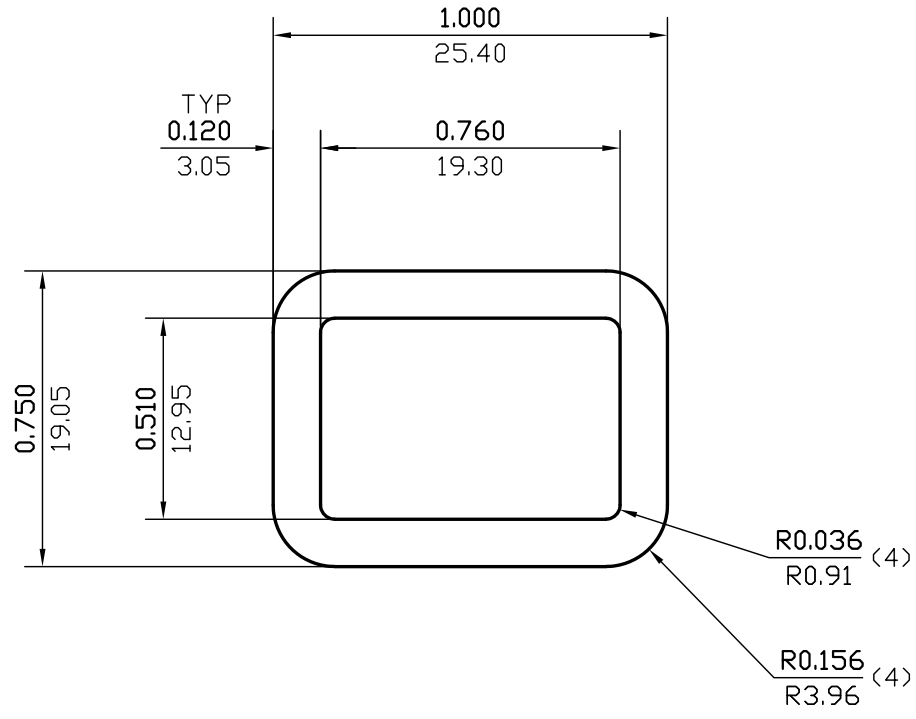

ACTUAL SIZE

WALL THICKNESS 0.120 (3.05) EXCEPT AS SHOWN

DATE	REV	DESCRIPTION	BY
03/15/23	1	REMOVED ALLOY	JASON
EST.AREA	0.343	IN. ²	EST.AREA 221.048
			MM. ²
EST.WT.	0.404	LBS./FT.	EST.WT. 0.602
			KG/M.
EST.PER.	5.710	IN.	EST.PER. 145.043
			MM.
OUT PER.	3.232	IN.	OUT PER. 82.1
			MM.
C.C.D.	1.127	IN.	C.C.D. 28.627
			MM.
FINISH	M/F		ALLOY
CKD BY	FACTOR 14	SCALE 2:1	DWN BY P.M. DATE 05/28/2013

CAN ART

85 PARKSHORE DRIVE
BRAMPTON, ONT L6T 5M1
TEL. NO. (905) 791-1464
FAX NO. (905) 791-9151
WEB: www.canart.com

ALUMINUM EXTRUSION INC.

THIS DRAWING IS NOT NECESSARILY A COPY OF YOUR ORIGINAL. PLEASE APPROVE DIMENSIONS AND TOLERANCES INDICATED. CAN ART ASSUMES NO RESPONSIBILITY EITHER TECHNICAL OR LEGAL FOR HAVING THIS SHAPE MADE. THE CUSTOMER AGREES TO FULLY PROTECT CAN ART ALUMINUM FROM CLAIMS OF OTHERS RESULTING FROM THIS SHAPE.

SIGNED: _____ DATE: _____